



Vosoritide (VOXZOGO[®]▼) dosing and administration guide

Your guide to making daily
injections as easy as possible

What is vosoritide?

Vosoritide is a prescription medicine used for the treatment of achondroplasia in children 4 months of age and older whose bones are still growing.

This material is only for caregivers of patients who have been prescribed vosoritide. It is an additional information resource that should be read alongside the package leaflet. Always refer to the package leaflet before beginning treatment with vosoritide. If you have any questions, please discuss them with your child's doctor.

Reporting of side effects: If your child gets any side effects, talk to your child's doctor or nurse. This includes any possible side effects not listed in the package leaflet. By reporting side effects you can help provide more information on the safety of this medicine.

▼ This medicinal product is subject to additional monitoring. This will allow quick identification of new safety information. You can help by reporting any side effects directly to BioMarin via drugsafety@bmrn.com; Fax: +1-415-532-3144 or Tel: +1-415-506-6179. Reporting of side effects is also possible via national reporting systems.

Suspected Adverse Drug Reactions (side effects) or medication errors may be reported using the Medicines Authority ADR reporting form, which is available online at <http://www.medicinesauthority.gov.mt/adrportal>, and sent by post or email to; P: Pharmacovigilance Section at Post-Licensing Directorate, Medicines Authority, Sir Temi Zammit Buildings, Malta Life Sciences Park, San Ġwann SĠN 3000 E: postlicensing.medicinesauthority@gov.mt

B:OMARIN[®]

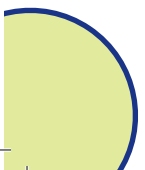
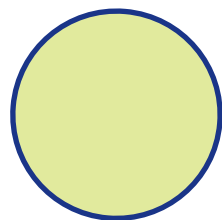
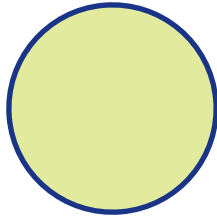
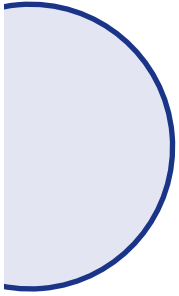

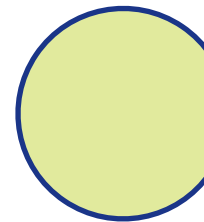

Contents

Prepare your supplies	4-5
Prepare the injection	6-9
Select, clean & inject	10-11
The finish line	12
Storage & disposal	13
Helpful hints	14-15
Important notes	16

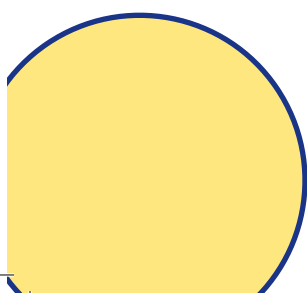
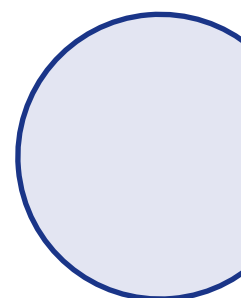

Prepare your supplies



Before touching the supplies, wash your hands and any surface the supplies might touch

What you'll need:

- A nice, calm environment where you and your child feel comfortable
- To consider what the best time each day would be to give your child their injection. It is important not to be rushed the first few times, so as to build both you and your child's confidence
- A light snack and drink for your child 30 minutes before can help stop them from feeling dizzy or weak after an injection. If your child is not on solid foods, make sure they have had a drink before the injection

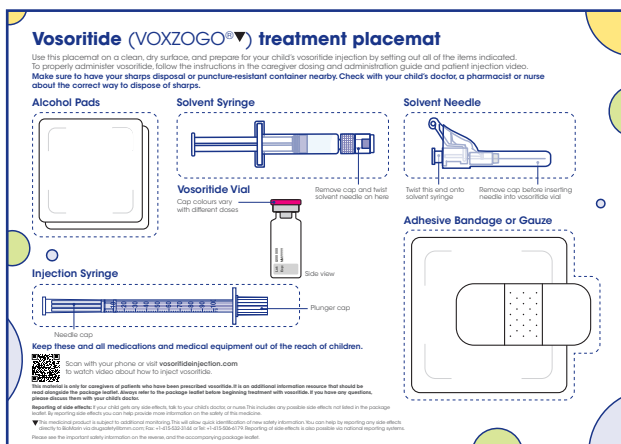

A clean surface to keep everything clearly laid out. If you have a placemat, you may use it once it has been cleaned.

Vosoritide Vial

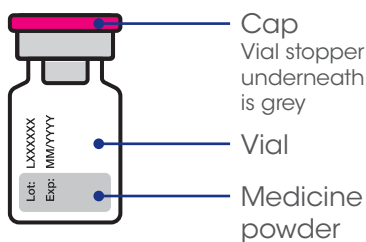

A **vial with medicine powder**. Check the expiry date and inspect for damage. Do not use anything that looks damaged or is out of date and discard in a sharps disposal or puncture-resistant container as per local regulations.

Verify you have the correct dosage by checking the label and colour of the vial cap.

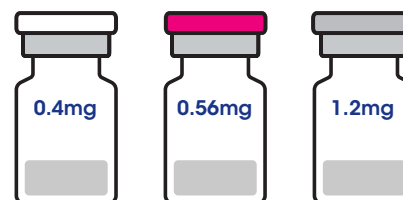

Solvent Syringe

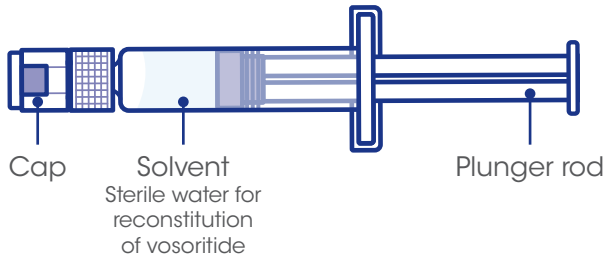

The **solvent syringe** contains sterile water to dissolve the **vosoritide powder**. Remove from refrigerator approx. 15–30 minutes before preparing the injection to allow to reach room temperature (depending on existing room temperature).

Solvent Needle

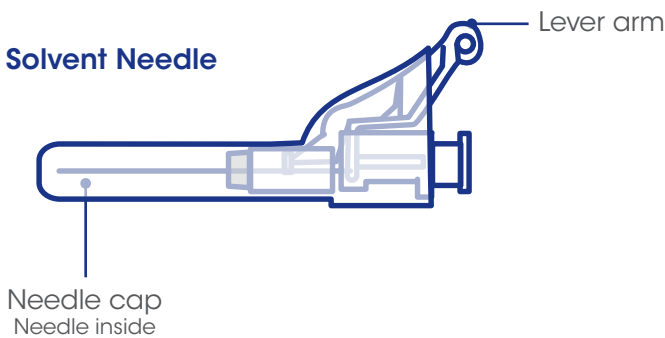

The **solvent needle** will be attached to the solvent syringe so the sterile water can be injected into the **vial**.

Injection Syringe

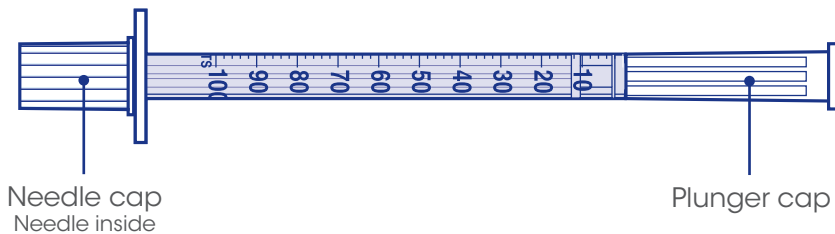

An **injection syringe**. It is thin and already has a needle attached.



Alcohol Pads



Sharps Container

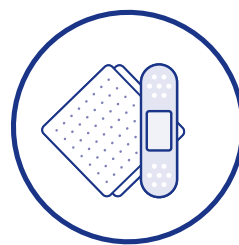

Adhesive Bandage or Gauze

You will require the items on the left. Check with your child’s doctor, a pharmacist or nurse about the correct way to dispose of sharps. A pharmacist can help you find these items (not included with the product).



It’s important to administer vosoritide around the same time each day. If a dose is missed and cannot be taken within 12 hours, skip that dose and take the next dose at the usual time of administration

Prepare the injection

How to prepare the injection syringe

Begin by washing your hands with soap and water and dry them thoroughly using a paper towel or a clean hand towel. Let your child watch if they would like to. Getting familiar with the components can help them feel part of their therapy.

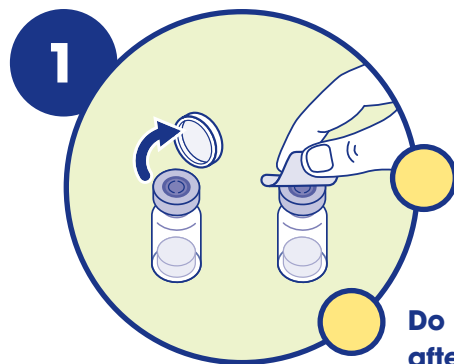

On a clean flat surface, flip off the vial cap and wipe the top with an alcohol pad

Do not touch the vial stopper with your fingers after wiping it with the alcohol pad

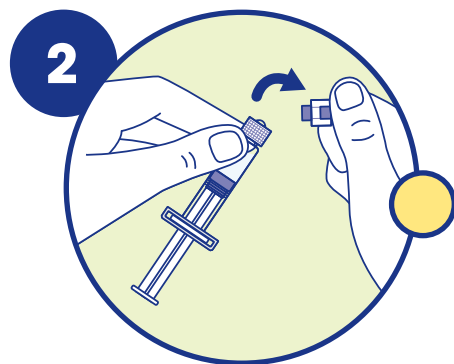

Gently bend to snap off the cap from the **solvent syringe**

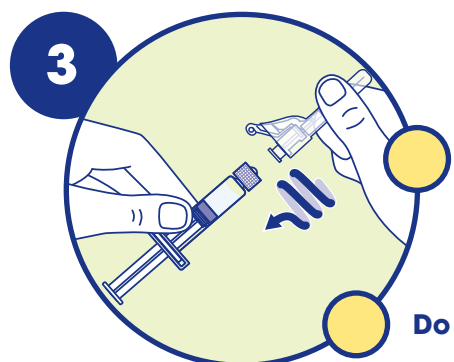

Twist the **solvent needle** onto the **solvent syringe** until you can no longer twist it

Do not use the solvent syringe to give the injection

Pull off the **needle** cap and insert the needle into the vial through the middle of the **vial** stopper

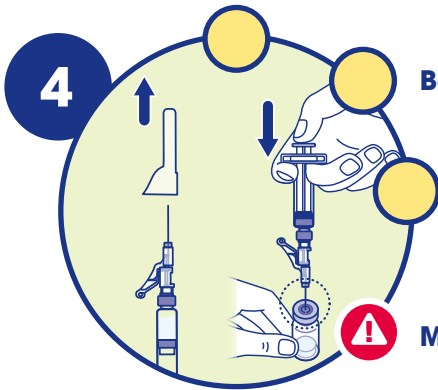

4

Be careful not to point the exposed needle at anyone

Slowly push the plunger rod down to inject all of the liquid. Do not push quickly or it may create bubbles

Make sure you inject through the middle of the vial stopper

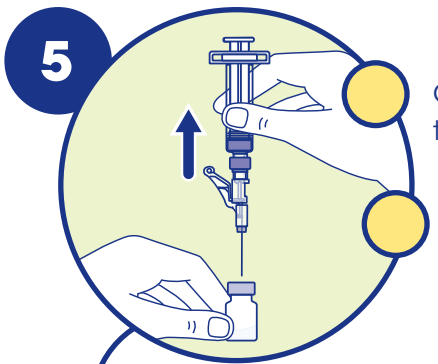

5

Once there is no more sterile water in the syringe, remove the **solvent needle** from the vial

Be careful not to touch the needle tip

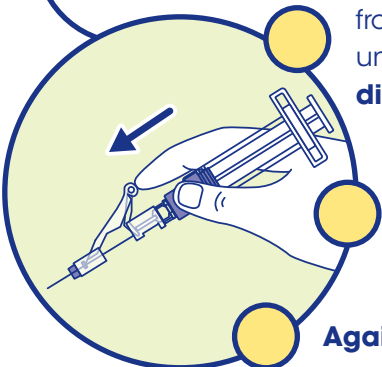

Activate the safety mechanism immediately after removal from the vial by pushing the lever arm completely forward until the tip is completely covered. **If unable to activate, discard immediately into a sharps container**

Throw away the used **solvent needle** and **syringe** in your nearby sharps container

Again, do not use the solvent syringe to give the injection

Prepare the injection

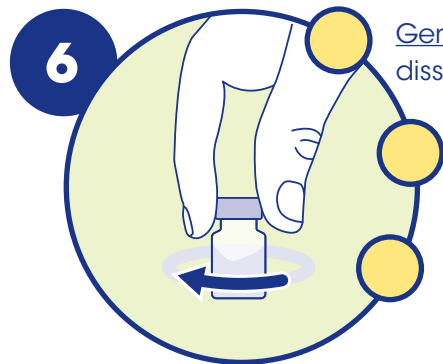

Gently swirl the **vial** until the powder has completely dissolved and the solution is clear. **Do not shake**

The powder may take longer to dissolve in colder environments

Examine the **vial** to make sure the medicine:

- is clear to yellow
- is not cloudy
- does not contain particles

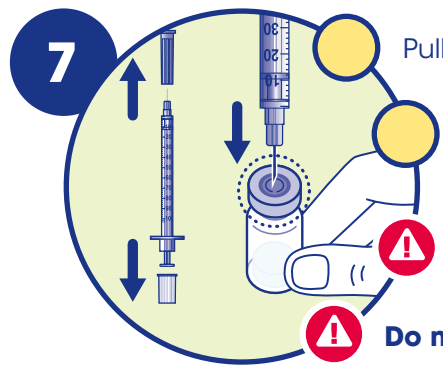

Pull off the caps from the top and bottom of the injection syringe

Insert the needle straight through the middle of the vial stopper, taking care not to touch the sides of the stopper

Be careful not to bend the injection needle

Do not place the cap back on the needle

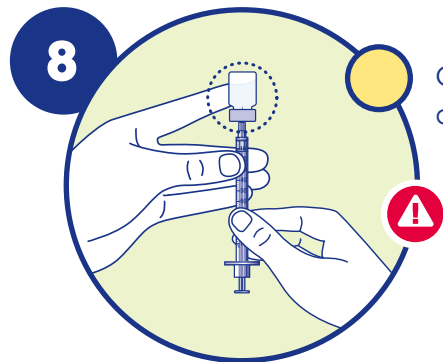

Carefully hold the **vial** and **syringe** and turn the vial upside down with the needle still inserted. The vial should be on top

Be careful not to bend the needle

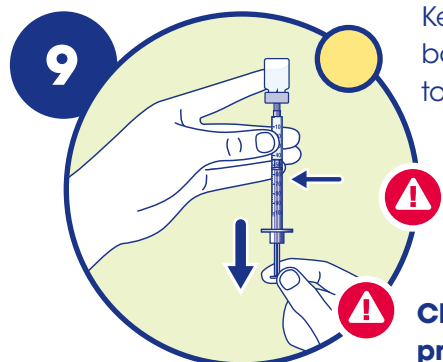

Keep the **needle tip** in the **medicine** and slowly pull the plunger rod back to draw up the prescribed dose in the syringe. Support the vial to avoid bending the needle

Check the prescription label for how much to draw up

Check the syringe provided in the pack and draw up the prescribed dose

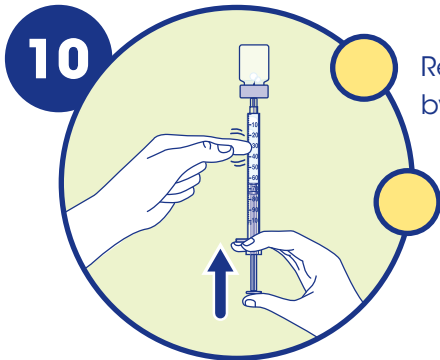

10

Remove large air bubbles in the syringe by gently tapping the **syringe**

Slowly push the bubbles back into the **vial**

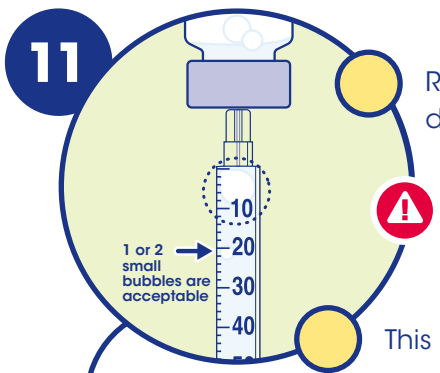

11

Repeat steps 9 and 10 until you have the correct prescribed dose in the **injection syringe** and no large bubbles

Remove any large bubbles. One or two small bubbles are ok

This step can feel strange at first, but will get easier with practice

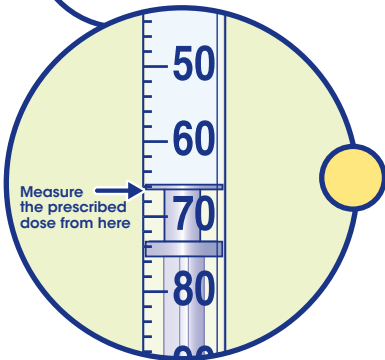

Make sure the dose in the syringe matches the prescribed dose. Measure from the base of the plunger as shown

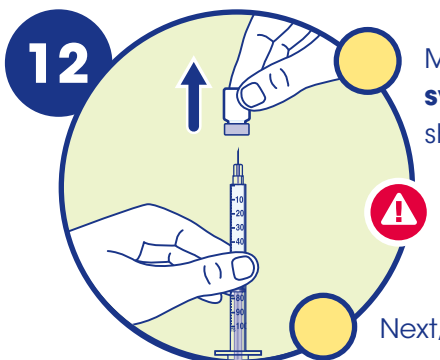

12

Make sure you have the prescribed dose in the **injection syringe**, then remove and discard the **vial** in the nearby sharps disposal container, even if there's leftover liquid

Confirm amount matches the prescribed dose before removing vial

Next, prepare to give the dose

Select, clean & inject

Select the site

Vosoritide should only be injected into the fatty layer under the skin (subcutaneous). There are 4 places you can inject vosoritide:

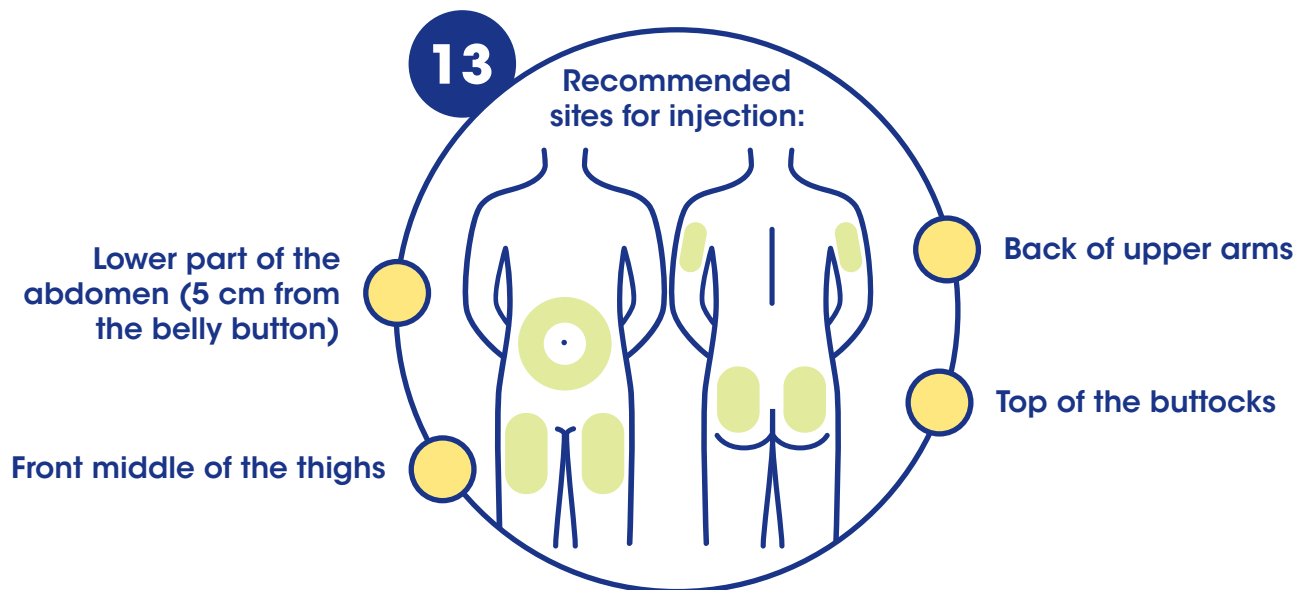

In young children, the recommended site for injections is thighs. Upper arms and buttocks can also be considered.

Make sure to pick a different site from the day before

- Do not inject in the same site twice in a row – the injection should be at least 5 cm from the last injection. You can use the treatment calendar provided by your child’s care team to keep track of where you give the injection each day
- Do not inject through clothes
- Avoid sites if you notice red, hard, bruised, or scarred skin. If your child is uncomfortable with a specific spot, it’s okay to select a different location for the injection

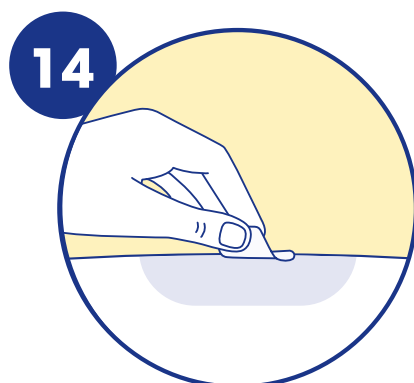

Clean the site

Wipe the injection site with an alcohol pad and let the skin air-dry. **Do not touch the area again before the injection**

Inject in 3 steps - PINCH, RELEASE, PUSH

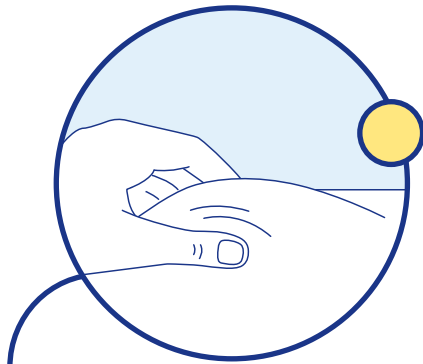

After wiping the selected injection site with an alcohol pad, gently **PINCH** the skin up around the injection site

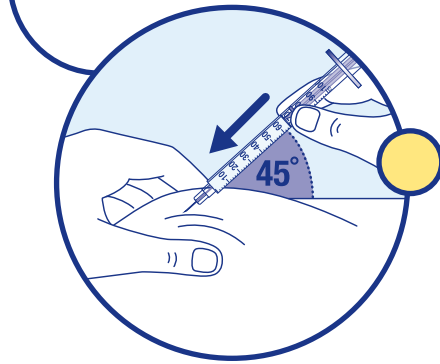

Quickly insert the **injection needle** all the way into the skin at a 45-degree angle

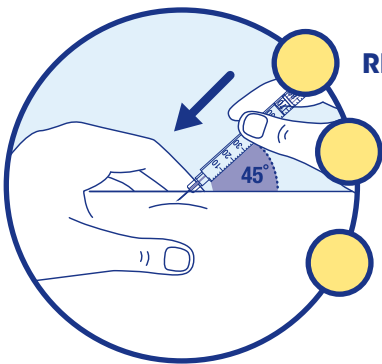

RELEASE the pinch

It may help to stabilise the syringe with one hand while pushing the plunger down with the other

This step can feel difficult at first, but will get easier with practice. It may help to ask another adult to support with steadying your child whilst you administer the injection

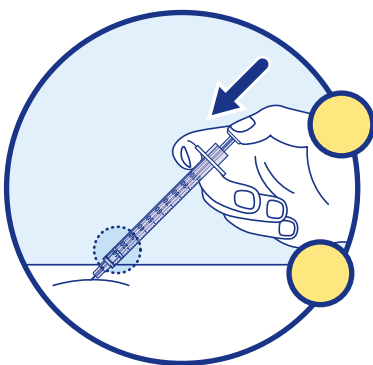

Slowly **PUSH** the plunger rod all the way down. This could take between 0-30 seconds depending on the volume of the injection

Inject the full dose



Throw away the **used vial, syringes** and **needles** in your nearby sharps disposal container (see 'How to dispose of vosoritide' on page 13)

The finish line

Check the site and encourage conversation

After every injection, have a short talk with your child about how they feel. Take a close look at the injection site – if it's bleeding a little, gently press it with gauze for a few seconds or apply an adhesive bandage. **Do not** rub the injection site.

Watch for signs of low blood pressure, such as dizziness, tiredness or feeling sick. If you see these symptoms, call the doctor or healthcare provider, then have your child lie back with their feet raised.



Dizziness



Tiredness



Feeling sick

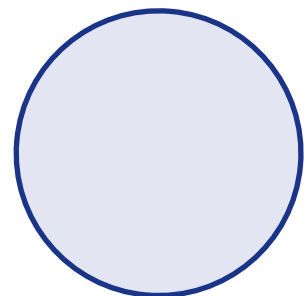
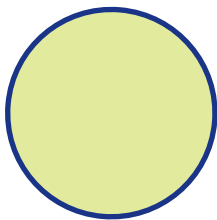

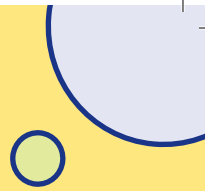

Storage & disposal

How to store vosoritide materials before injection

- Store vosoritide vials in a refrigerator at 2°C – 8°C. The vosoritide vial should be removed from the refrigerator and allowed to reach room temperature before preparing vosoritide for injection. **Do not freeze**. Store in the original package to protect from light
- Keep this medicine **out of the sight and reach of children**
- Vosoritide may be stored at room temperature (below 30°C) for **up to 90 days**, but not beyond the expiry date. **Do not** return vosoritide to refrigerator after storage at room temperature. **Record** on the carton **the date** you remove vosoritide from the refrigerator to store at room temperature
- **Do not** use vosoritide after the expiry date
- Use vosoritide as soon as it has been made up as a solution. In any case it must be given within 3 hours of making it up. Do not use if the injection solution is cloudy or contains any particles

How to dispose of vosoritide materials after the injection

- Put your used or expired vials, needles, and syringes in an approved sharps disposal or puncture-resistant container right after use. Check with your doctor, pharmacist or nurse about the correct way to dispose of sharps
- When your sharps disposal container is almost full, follow your local guidelines for disposal
- Do not dispose of loose materials or a full sharps container in your household waste unless your local guidelines permit this
- Do not reuse sharps disposal containers

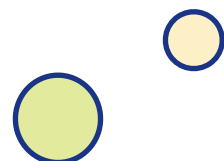

Helpful hints

Here are some tips that could help you and your child get used to taking vosoritide every day.

Tips for daily administration

Staying on track with daily injections is important to get the most of vosoritide. You may find the following ideas useful to help successfully incorporate it into your daily routine.

- **Create a positive environment** – it's okay to be nervous; it's okay to be brave
- **Like clockwork** – a daily injection routine can help make the process easier
- **Injections are only scary if we make them scary** – encourage open communication about how the process makes them feel
- Model and explain why **clean hands are important** when handling the medication and materials
- **Every child is different when it comes to managing daily injections.** Some may be interested in being involved with the injection process, others may not. For those who do not, consider using distraction techniques with your child such with their favourite TV program or video game
- Consider, if appropriate, a reward for your child on successfully completing each injection
- It can be useful to have **more than one** caregiver trained to administer the vosoritide injection. One adult can support with steadying your child whilst the other administers the injection
- **Do not** administer the injection whilst your child is sleeping

For more independent children

- Sometimes, the easiest way to inject vosoritide is while they're doing something they love. It's okay if they want to play a video game or watch TV – as long they keep listening to instructions



Scan with your phone or visit vosoritideinjection.com to watch a video on how to inject vosoritide.

For younger children

Using the bear hug technique to hold your child can help reduce stress and prevent movement during administration. You might need to ask another adult to help.

- Your child should sit on your lap facing you
- Your child's legs should wrap around your waist
- Wrap your arms around the child's upper and lower back
- Hold your child firmly
- Your child can turn their head and put it on your chest

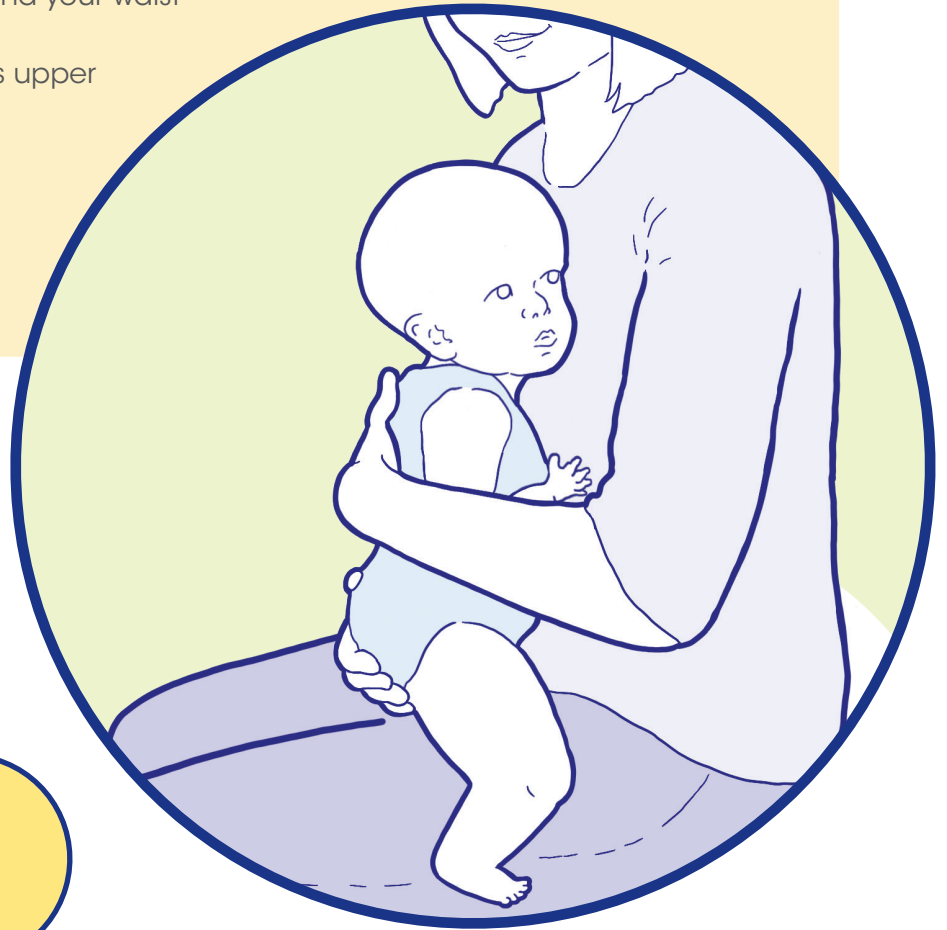

Important notes

What is vosoritide?

Vosoritide is a prescription medicine used for the treatment of achondroplasia in children 4 months of age and older whose bones are still growing.

What do you need to know before you use vosoritide?

Do not use vosoritide

- If your child is allergic to vosoritide or any of the other ingredients of this medicine listed in the package leaflet

Warnings and precautions

Talk to your child's doctor before using vosoritide:

- If your child has significant heart disease or blood pressure problems
- If your child is taking or has recently taken medicines that lower blood pressure

If any of these apply to your child or you are unsure, talk to your child's doctor before using vosoritide.

Vosoritide can lower blood pressure. As a result, your child may feel dizzy, nauseous, or tired. Blood pressure usually returns to normal within 90 minutes of vosoritide injection. If these effects occur and are severe, tell your child's doctor. Drinking plenty of fluids at the time of injection may reduce the likelihood of these effects. It is recommended patients eat a light snack and drink enough fluid (e.g. water, milk or juice) about 30 minutes before injection.

Other medicines and vosoritide

Tell your child's doctor if your child is taking, has recently taken or might take any other medicines.

Pregnancy and breast-feeding

If your child is being treated with this medicine and is pregnant or breast-feeding, think they may be pregnant or are planning to have a baby, ask their doctor for advice before using this medicine. The use of this medicine is not recommended during pregnancy and breast-feeding.

Driving, cycling and using machines

This medicine may cause your child to feel dizzy, light-headed, tired or your child may feel sick shortly after their injection. If this happens, they should not drive, ride a bicycle, do physical activities or use machines for around an hour after injection or until they feel better.

Vosoritide contains sodium

This medicine contains less than 1 mmol sodium (23mg) per dose, that is to say essentially 'sodium-free'.

Important notes

If you use more vosoritide than you should

If you inject more vosoritide than you should, contact your child's doctor straight away.

If you forget to use vosoritide

If your child misses a dose, the injection should still be given if it is within 12 hours of the scheduled time. If more than 12 hours have passed since the scheduled dose time, do not inject the missed dose. Wait until the next day and continue with the usual dose at the usual time.

If you stop using vosoritide

Always talk to your child's doctor before deciding to stop your child's treatment. If you have any further questions on the use of this medicine, ask your child's doctor or pharmacist.

Please see accompanying package leaflet.

Travelling with vosoritide

Short- and long-term travel requires considerable planning and organisation. Bring enough treatment supply and injection materials with you in case of unforeseen circumstances, e.g. if a needle breaks, etc. Keep the treatment reliably cool. Make sure to give injections to your child at a suitable time.

Reporting of side effects

If your child gets any side effects, talk to your child's doctor, or nurse. This includes any possible side effects not listed in the package leaflet. By reporting side effects you can help provide more information on the safety of this medicine.

Vaccination

Vosoritide can be given at the same time your child receives a vaccination. The sites of administration of both injections should not be the same.

B:OMARIN®

Developed and Funded by BioMarin International Ltd.
© 2024 BioMarin International Ltd. All rights reserved.
EUCAN-VOX-00240 April 2024